



**PSDC 08128**

v.1.2

**PSDC 12V/8A/8x1A**  
**Switched mode power supply for CCTV.**

EN\*\*

Edition: 6 from 26.07.2013

Supersedes the 5 from 10.12.2012edition



### Features:

- supply output 8x 1A/12V DC
- output voltage adjustment 12V÷ 15VDC
- 8 outputs protected with 1A fuses
- jumper selectable fuses: glass fuse or polymer fuse
- wide range of supply voltage 176÷264VAC
- high efficiency 83%
- LED indication
- AW technical output of fuse activation indication
- protections:
  - SCP short-circuit protection
  - OVP over voltage protection
  - surge protection
  - OLP overload protection
  - against tampering
- warranty – 2 year from the production date

### CONTENTS:

1. Technical description.
  - 1.1 General description
  - 1.2 Block diagram
  - 1.3 Description of PSU components and connectors
  - 1.4 Specifications
2. Installation.
  - 2.1 Requirements
  - 2.2 Installation procedure
3. Operating status indication.
  - 3.1 LED indication
  - 3.2 Technical outputs
4. Operation and use.
  - 4.1 Overload or short circuit at the PSU output
  - 4.2 Activation of the OVP system of the PSU
  - 4.3 Maintenance

### 1. Technical description.

#### 1.1 General description.

The stabilized PSU **PSDC08128** is intended for supplying CCTV devices requiring stabilised voltage of **12V DC**. The output voltage adjustment range is adjusted via a potentiometer within the range of **12V÷15V DC**. The PSU features 8 outputs protected independently by either glass fuses or polymer fuse.

A failure (a short circuit) in the output circuit makes a fuse blow or an activation of the polymer fuse and disconnection of the circuit from the DC power supply (+U). The PSU is housed in a metallic enclosure with an indication panel featuring a microswitch indicating unwanted opening of the door (faceplate).

#### 1.2. Block diagram. (fig.1).

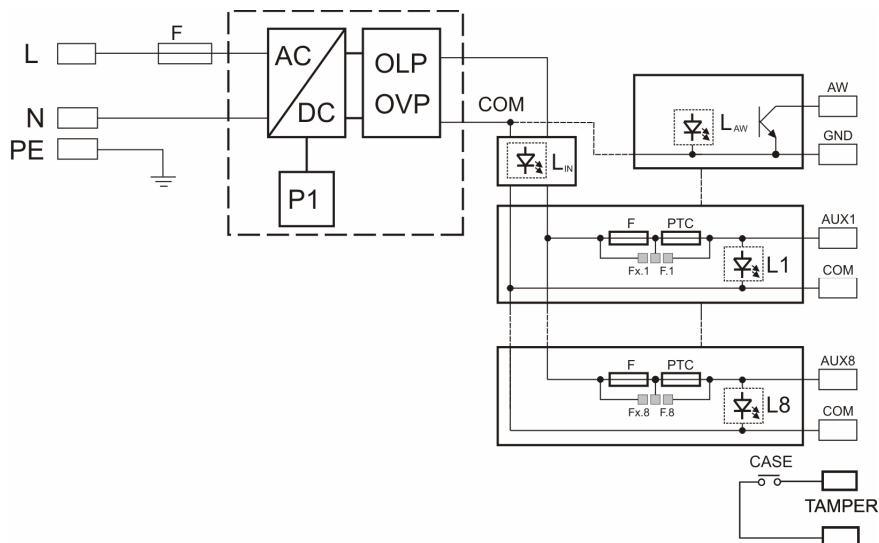





Fig.1. Block diagram of the PSU.

1.3. Description of PSU components and connectors.

Table 1. Elements of the PSU pcb (see fig. 2).

Element no.	Description
[1]	L1.....L8 (green) LEDs (indicating fuse activation)
[2]	F1...F8 glass fuses in AUX (+) circuits
[3]	IN supply input of the LB8/AW strip
[4]	AUX1.... AUX8 outputs, COM (-) shared terminal
[5]	L <sub>AW</sub> (red) diode indicating failure of a particular output (fuse activation)
[6]	AW output indicating failure of a particular output, OC type (normal status: L, failure: hi-Z)
[7]	Jumper for the selection of the fuse type: Fx Fx.x   Fx jumper on – polymer fuse Fx Fx.x   Fx.x jumper off – glass fuse

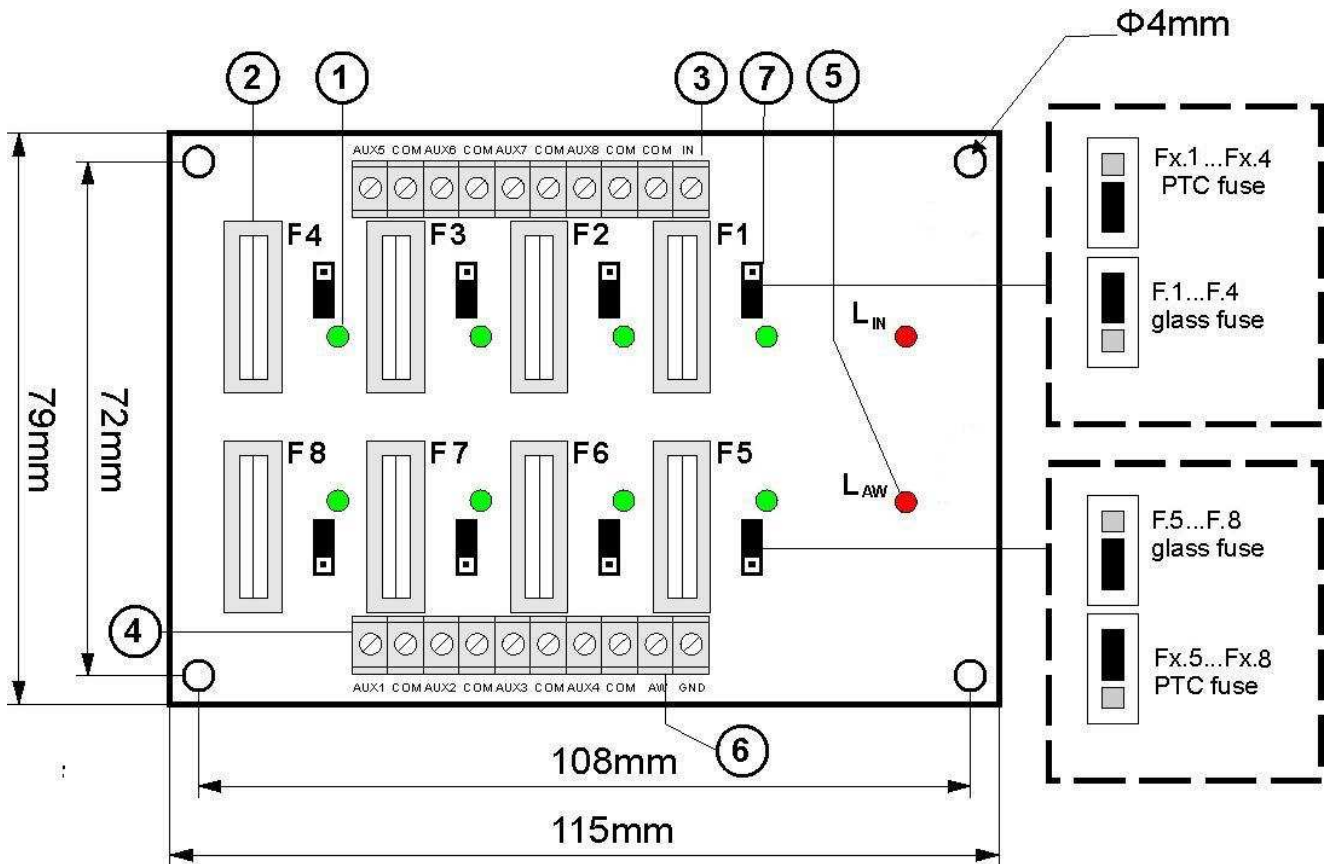

Fig.2. The view of the PSU's pcb.

Table 2. Elements of the PSU (see fig. 3).

Element no.	Description
[1]	L-N 230 V AC power connectors, PE protection connector
[2]	LED indication of DC power status, main module of the PSU
[3]	PSU module
[4]	V <sub>ADJ</sub> , potentiometer, output voltage adjustment within the range of 12,0V÷15,0V DC
[5]	LB8/AW fuse strip, with power outputs and LED indication
[6]	Tamper, contact of tampering protection (NC)

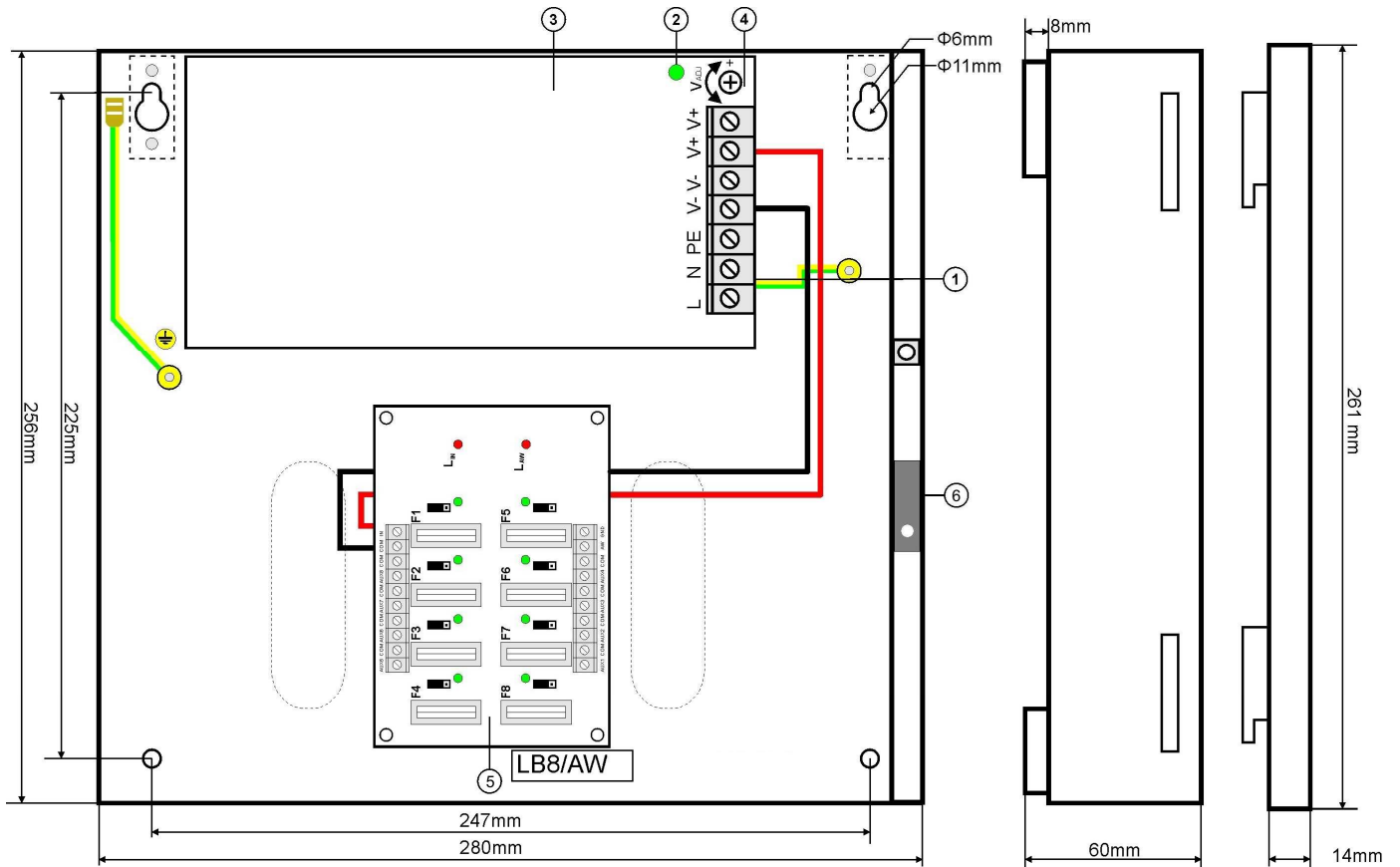

Fig.3. The view of the PSU.

**1.4. Specifications:**

- electrical specifications (tab.3)
- mechanical specifications (tab.4)
- operation safety (tab.5)
- operating specifications (tab.6)

**Electrical specifications (tab. 3).**

Supply voltage	176 ÷ 264V AC
Current consumption	0,9A@230VAC max.
PSU power	120W max.
Efficiency	83%
Output voltage	12V DC
Output current	8 x 1A
Output voltage adjustment range	12V ÷ 15VDC
Ripple voltage	100mV p-p max.
Short-circuit protection SCP	LB8/AW STRIP 8x F 1A fuse or PTC 1A PSU MODULE 105% ÷ 150% of PSU power, electronic current limiting
Overload protection OLP	105% ÷ 150% of PSU power, electronic current limiting
Surge protection	varistors
Surge over voltage protection OVP	>16V (activation requires disconnecting the load or supply for about 20 s.)
Tampering protection system TAMPER – indicating unwanted opening of the PSU's enclosure	- microswitch, NC contacts (enclosure closed), 0,5A@50 V DC (max.)
Technical outputs: - AW outputs indicating fuse failure (blow) of LB8/AW strips: (SCP activation)	OC type, 50mA max, normal status: L level (0V), failure: hi-Z level
F1 ÷ F8 fuses	F 1A/250V or PTC 1A (manual selection)

**Mechanical specifications (tab. 4).**

Enclosure dimensions	280 x 256 x 58 (285 x 261 x 50+8) (WxHxD) [mm] (+/- 2)
Fixing	247 x 225 x $\Phi$ 6 (WxH)
Net/gross weight	1,96/2,25 kg
Enclosure	Steel plate, DC01 0,7mm colour: RAL 9003
Closing	Cheese-head screw: at the front
Connectors	Power supply: 230V AC: $\Phi$ 0,63-2,05 (AWG 22-12) AUX outputs: $\Phi$ 0,51- 2,05 (AWG 24-12) LB8/AW: $\Phi$ 0,51- 2,05 (AWG 24-12) TAMPER output: wires 25cm
Notes	The enclosure does not adjoin the assembly surface so that cables can be led. Convictional cooling.

**Operation safety (tab.5).**

Protection class PN-EN 60950-1:2007	I (first)
Protection grade PN-EN 60529: 2002 (U)	IP20
Electrical strength of insulation: - between input (network) circuit and output circuits of the PSU (I/P-O/P) - between input circuit and PE protection circuit (I/P-FG) - between output circuit and PE protection circuit (O/P-FG)	3000V/AC min. 1500V/AC min. 500V/AC min.
Insulation resistance: - between input circuit and output or protection circuit	100 M $\Omega$ , 500V/DC

**Operating specifications (tab.6).**

Operating temperature	-10°C...+50°C
Storage temperature	-25°C...+60°C
Relative humidity	20%...90%, without condensation
Vibrations during operation	unacceptable
Impulse waves during operation	unacceptable
Direct insolation	unacceptable
Vibrations and impulse waves during transport	PN-83/T-42106

**2. Installation.****2.1 Requirements.**

The stabilized PSU is to be mounted by a qualified installer, holding relevant permits and licenses (applicable and required for a given country) for 230V/AC interference and low-voltage installations. The unit should be mounted in confined spaces, in accordance with the 2nd environmental class, with normal relative humidity (RH=90% maximum, without condensation) and temperature from -10°C to +50°C. The PSU shall work in a vertical position that guarantees sufficient convectional air-flow through ventilating holes of the enclosure.



**During normal operation the total current consumption of the receivers cannot exceed  $I=8x1A$**

As the PSU module is designed for a continuous operation and is not equipped with a power-switch, therefore an appropriate overload protection shall be guaranteed in the power supply circuit. Moreover, the user shall be informed about the method of unplugging (most frequently through separating and assigning an appropriate fuse in the fuse-box). The electrical system shall follow valid standards and regulations.

**2.2 Installation procedure.**

- 1. Before installation, make sure that the voltage in the 230V power-supply circuit is cut off.**
- Mount the PSU in a selected location and connect the wires.
- Connect the power cables (~230VAC) to L-N terminals of the PSU. Connect the ground wire to the terminal marked by the earth symbol. Use a three-core cable (with a yellow and green PE protection wire ) to make the connection. Lead the cables to the appropriate terminals of the connection board through the bushing.



The shock protection circuit shall be performed with a particular care, i.e. the yellow and green wire coat of the power cable shall stick to one side of the terminal marked with the '⊖' earth symbol in the PSU enclosure. Operation of the power supply without a properly made and fully operational shock protection circuit is **UNACCEPTABLE!** It can result in device damage or an electric shock.

4. Connect the receivers' cables to the **AUX1...AUX8** connectors on the **LB8/AW ) strips**.
5. If necessary, connect the device's wires (of an alarm panel, controller, indicator, etc.) to the technical outputs:
  - **AW (LB8/AW )** output indicating a fuse failure (outputs of the LB8/AW fuse strips).
  - **TAMPER** output indicating unwanted opening of the PSU's enclosure.
6. In electrical installations with significant voltage drops in the resistance of the wires that lead to the receivers, the voltage value can be corrected with the P1 potentiometer (12,0V÷15,0V DC).
7. Check the PSU operating status indication
8. Once the installation and operation control have been completed, the enclosure can be locked.

### 3. Operating status indication.

The PSU is equipped with LED indication of operation status. The presence of power at the outputs of the PSU is indicated by the illumination of green LEDs on the front panel of the device. AW red LED [!] indicates a failure. The status of the PSU can be remote controlled by the AW technical output.

#### 3.1. LED indication (fig.4.).

- **LED1...LED8** green diodes indicate power at the outputs: LB8AUX1.....AUX8.  
In case of a power loss at the output (fuse activation), an appropriate diode goes out. (L1 for AUX1, L2 for AUX2 etc.)
- **AW red LED [!]** indicates a failure of at least one AUX output (the output's number is indicated by the green diode).

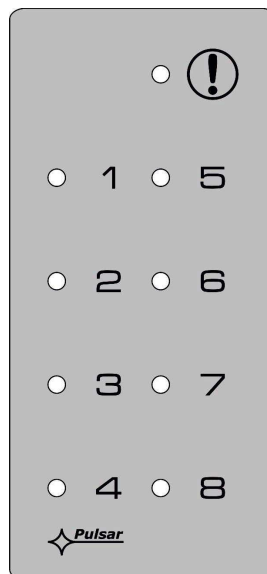

Fig. 4 The view of the PSU panel.

#### 3.2 Technical outputs.

The PSU has indication outputs that allow transferring information about a failure or tampering.

- **AW** - output indicating a fuse failure (outputs of the LB8/AW fuse strip).  
The AW technical output during correct operation of the PSU is ground fault (GND). Failure of one of the fuses opens the output – high impedance state. The failure is also indicated by the  $L_{AW}$  red diode.

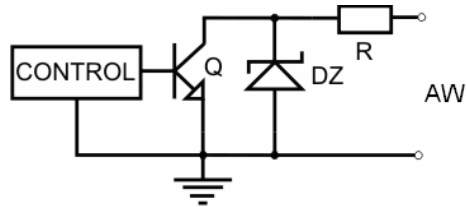

Fig. 5. Electrical diagram of the OC output.

- **TAMPER** – output indicating unwanted opening of the PSU, contains volt-free (potential-free) contacts indicating the door status - unit closed: NC, unit opened: NO.

#### 4. Operation and use.

##### 4.1 Overload or short circuit at the PSU output.

The AUX1 ÷ AUX8 PSU outputs of the LB8/AW strips are protected against a short circuit by glass fuses or polymer fuses. If a fuse-assisted protection has been chosen, replace the fuse (of the same parameters) in case of a failure. If the polymer fuses-assisted protection has been chosen, there will be an automatic disconnection of the output voltage indicated by the green diode going out. Then, cut off the load from the PSU output for approx. 1 minute.

##### 4.2. Activation of the OVP system of the PSU.

When the OVP system is activated, the output voltage is automatically cut off. Restart is possible after disconnecting the PSU from the mains supply 230V for at least 20 seconds.

##### 4.3. Maintenance.

Any and all maintenance operations may be performed following the disconnection of the PSU from the power supply network. The PSU does not require performing any specific maintenance measures. However, in case of significant dust level, clean its interior with compressed air. In case of a fuse exchange, use the replacement of the same parameters.

**WEEE MARKING**

**According to the EU WEE Directive – It is required not to dispose of electric or electronic waste as unsorted municipal waste and to collect such WEEE separately.**

**GENERAL WARRANTY CONDITIONS**

1. Pulsar K. Bogusz Sp.j. (the manufacturer) grants a two-year warranty for the equipment, counted from the device's production date.
2. The warranty includes free-of-charge repair or replacement with an appropriate equivalent (the selection is at the manufacturer's discretion) if the malfunction is due to the manufacturer, includes manufacturing or material defects, unless such defects have been reported within the warranty period (item 1).
3. The equipment subject to warranty is to be brought to the place where it was purchased, or directly to the main office of the manufacturer.
4. The warranty applies to complete equipment, accompanied by a properly filled warranty claim with a description of the defect.
5. Should the claim be accepted, the manufacturer is obliged to provide warranty repairs, at the earliest convenience, however not later than within 14 days from the delivery to the service centre of the manufacturer.
6. The repair period mentioned in item 5 may be prolonged, if there are no technical possibilities to carry out the repairs, or if the equipment has been conditionally accepted, due to the breaking warranty terms by the claimant.
7. All the services rendered by force of the warranty are carried out at the service centre of the manufacturer, exclusively.
8. The warranty does not cover the defects of the equipment, resulting from:
  - reasons beyond the manufacturer's control,
  - mechanical damage,
  - improper storage and transport,
  - use that violates the operation manual or equipment's intended use
  - fortuitous events, including lightning discharges, power failures, fire, flood, high temperatures and chemical agents,
  - improper installation and configuration (in defiance with the manual),
9. The warranty is void in any of the following circumstances:
  - construction changes
  - repairs carried out by any unauthorized service center
  - damage or removal of warranty labels
  - modifications of the serial number
10. The liability of the manufacturer towards the buyer is limited to the value of the equipment, determined according to the wholesale prices suggested by the manufacturer on the day of purchase.
11. The manufacturer takes no responsibility for the defects that result from:
  - the damaging, malfunctioning or inability to operate the equipment
  - defects that result from using the equipment outside its stated specifications and operating parameters failing to abide by the recommendations and requirements contained in the manual, or the use of the equipment.

**Pulsar K. Bogusz Sp.j.**

Siedlec 150, 32-744 Łapczyca, Poland  
Tel. (+48) 14-610-19-40, Fax. (+48) 14-610-19-50  
e-mail: [biuro@pulsar.pl](mailto:biuro@pulsar.pl), [sales@pulsar.pl](mailto:sales@pulsar.pl)  
http:// [www.pulsar.pl](http://www.pulsar.pl), [www.zasilacze.pl](http://www.zasilacze.pl)